

**Required Tools: (Not included)**

- A. Phillips screwdriver
- B. Flat head screwdriver
- C. 5 mm Allen wrench
- D. 2.5 mm Allen wrench

**⚠ WARNING**

**⚠ CAUTION:** To avoid potential shock or other injury, turn power switch **OFF** and disconnect charger before conducting any assembly or maintenance procedures. Failure to follow these steps in the correct order may cause irreparable damage.

**Step 1**

Using a Phillips screwdriver, remove two (2) screws from underneath the seat towards the back of the unit.

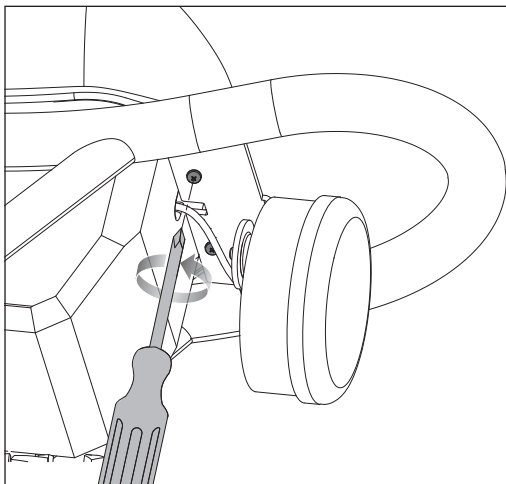
**Step 2**

Lift and pull back on the seat to remove.

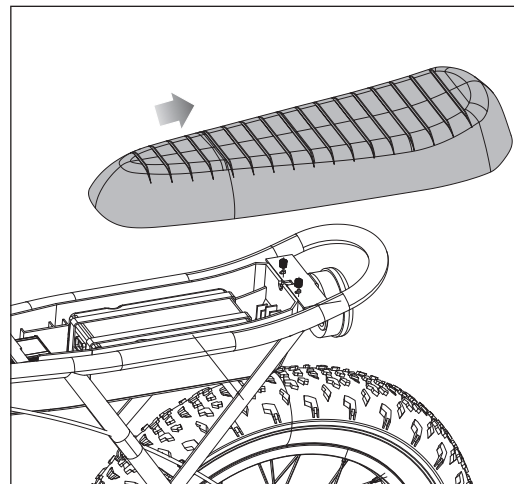

### Step 3

Locate and disconnect the brake lever switch from the controller.

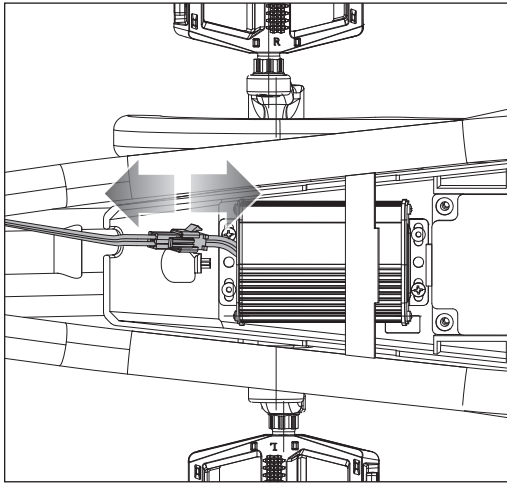

### Step 4

Using a 5 mm Allen wrench, loosen the bolt from the clamp on the brake lever .

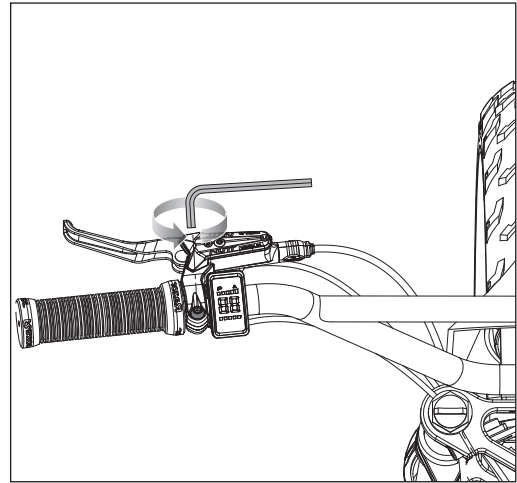

### Step 5

Using a 2.5 mm Allen wrench, loosen the set screw from the display and move the display and brake lever away from the grip.

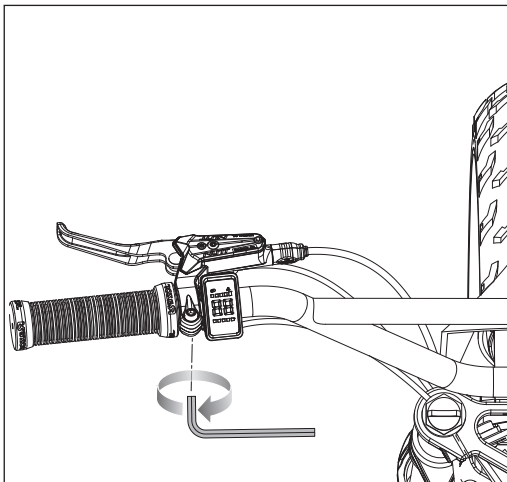

### Step 6

Using a flat screwdriver, insert the blade between the handlebar and the grip. Apply WD-40® or soapy water to remove the grip.

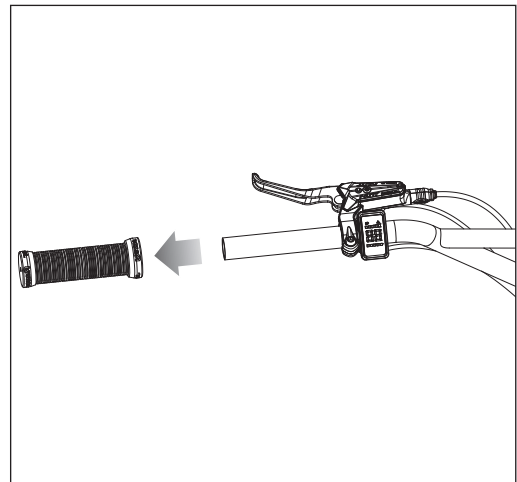

## Step 7

Using a 5 mm Allen wrench, loosen and remove the bolts that hold the caliper onto the fork.

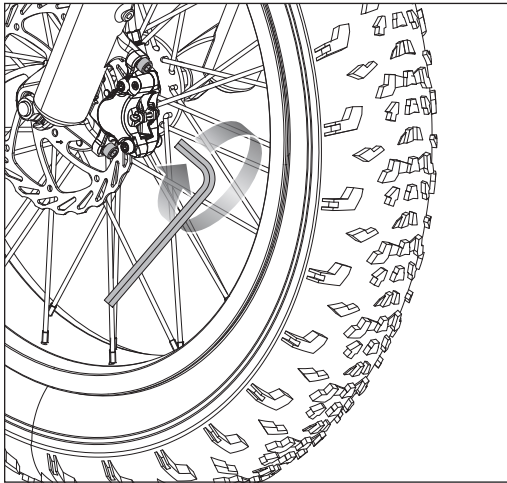

## Step 8

Remove caliper and brake from the unit.

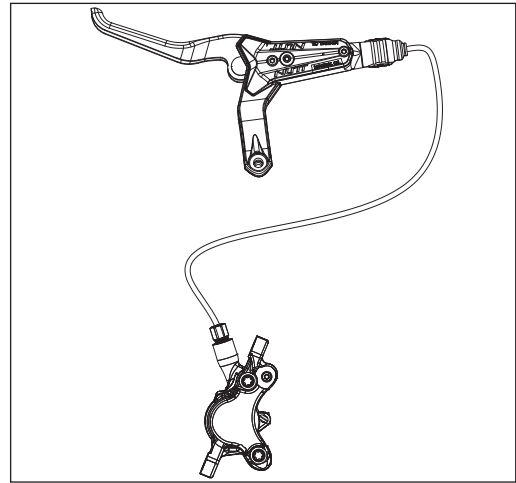

## Step 9

Reverse the steps to install the new brake lever and caliper. Once installed, reconnect the brake line to the brake lever. If the brakes feel loose or don't have enough braking power, it is possible that air may be trapped inside the line. If so, you may need to bleed the brakes. To do this, set the brake lever level to the ground and use a Torx T10 bit to loosen and remove the cap screw on top of the brake lever. Set the cap aside. Install a cup designed for bleeding brakes and fill to the middle with mineral oil. Squeeze the brake lever a few times to let the air out until there are no more bubbles emerging. Remove the cup and re-install the cap screw on the brake lever.

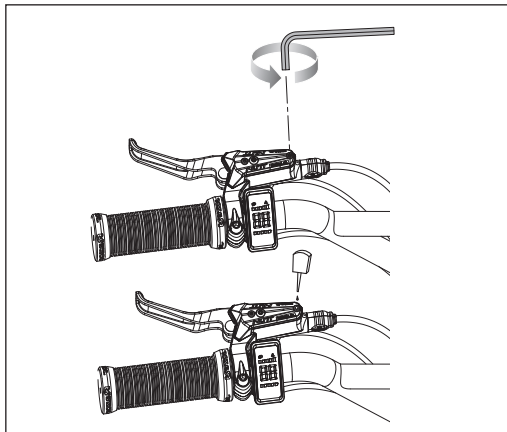

**ATTENTION: Charge battery 6 hours before using.**