

Required Tools: (Not included)

- 5 mm Allen wrench
- 10 mm wrench
- Phillips screwdriver

⚠ WARNING

⚠ CAUTION: To avoid potential shock or other injury, turn power switch **OFF** and disconnect charger before conducting any assembly or maintenance procedures. Failure to follow these steps in the correct order may cause irreparable damage.

Step 1

Remove the flag from the seat. Using a 5 mm Allen wrench, remove the four (4) screws on the seat.

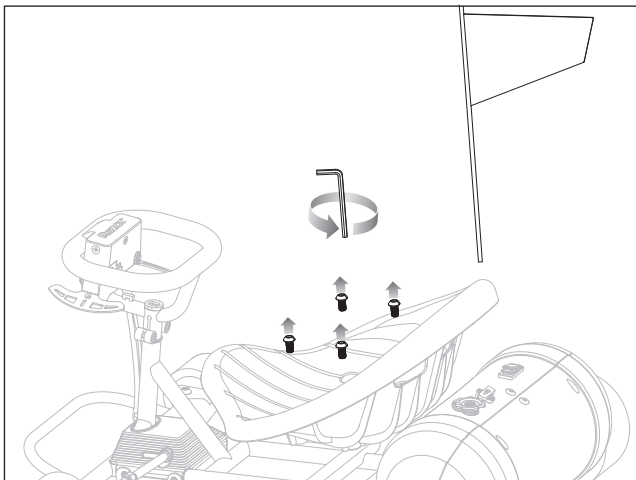
**Step 2**

Using a Phillips screwdriver, remove the five (5) screws on the rear battery cover.

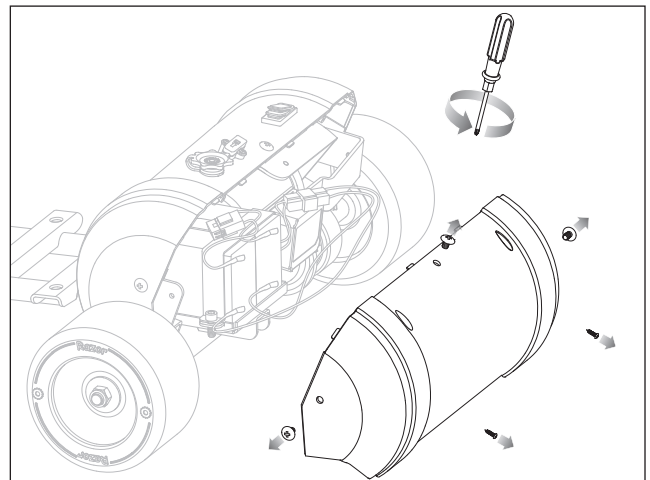

Step 3

Using a Phillips screwdriver, remove the three (3) screws on the front battery cover. Disconnect the plugs and remove the front cover.

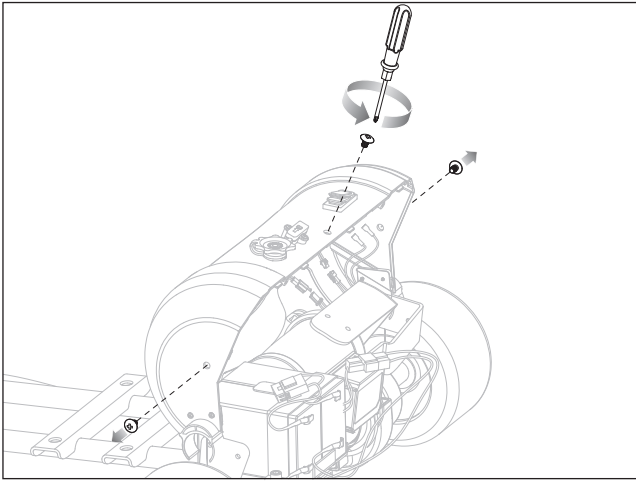

Step 4

Using a 10 mm wrench, remove the tensioner.

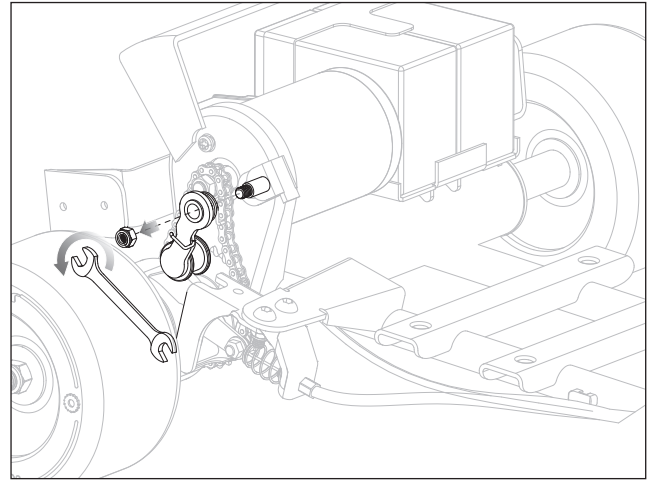

Step 5

To complete the assembly, please reverse steps 1 through 4.
ATTENTION: Charge battery 12 hours before using.

